

# SERIES 110

Solenoid Valve 2-way Normally Closed direct acting poppet type.

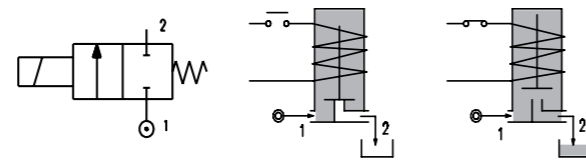

## SPARE PARTS LIST

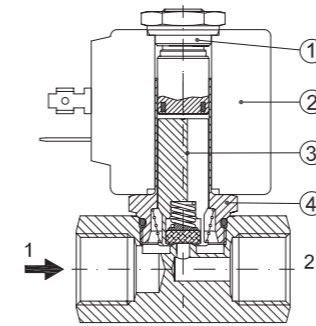

1. Coil fixing nut
2. Coil
3. Plunger
4. Armature tube assembly

Data in brackets are referred to coil series 4

## OVERALL DIMENSION

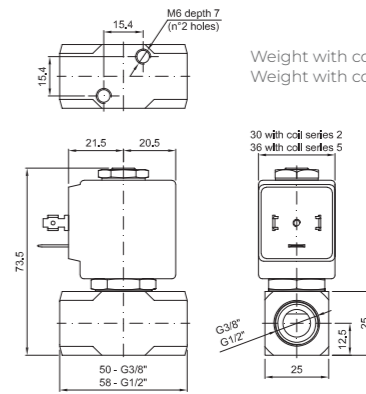

Weight with coil series 2=0.36Kg  
Weight with coil series 5=0.44Kg



## CONSTRUCTION

<b>BODY</b>	AISI 303
<b>ARMATURE TUBE</b>	AISI 303
<b>PLUNGER AND CORE</b>	AISI 430FR
<b>SPRINGS</b>	AISI 302
<b>SEAL MATERIAL</b>	NBR - FPM - EPDM - PTFE

## FEATURES

Maximum allowable pressure PS 100bar <sup>⑤</sup>
Maximum fluid viscosity 25cSt (mm <sup>2</sup> /s)
Ambient temperature: from -10°C to +80°C according to the coil
Universal mounting position

CODE ① ② ③	CONNECTION G ISO 228	ORIFICE [mm]	KV m <sup>3</sup> /h	DIFFERENTIAL PRESSURE [bar]		NOMINAL POWER			COIL		SEAL ②	TEMP. RANGE [°C]	
				MIN.	MAX.	AC	VA	DC	SERIES	WIDTH			
													AC
E110...10///...	1/4"	1	0.04	0	80	80	20	15	10	2	30	NBR=B	-10 +90
E110...12///...		1.2	0.05	0	60	60							
E110...15///...		1.5	0.07	0	30	26							
E110...20///...		2	0.1	0	22	20							
E110...25///...		2.5	0.15	0	16	14							
E110...30///...		3	0.25	0	15	10							
E110...35///...		3.5	0.32	0	10	8							
E110...40///...		4	0.36	0	8	5							
E110...45///...		4.5	0.41	0	6.5	3.5							
E110...52///...		5.2	0.47	0	4	1.8							
E110...64///...	6.4	0.64	0	3	1								
E110...10///...	3/8"	1	0.04	0	100	100	40	30	27	5	36	FPM=V	-10 +140
E110...12///...		1.2	0.05	0	100	100							
E110...15///...		1.5	0.07	0	80	80							
E110...20///...		2	0.1	0	50	40							
E110...25///...		2.5	0.15	0	35	33							
E110...30///...		3	0.25	0	25	24							
E110...35///...		3.5	0.32	0	20	19							
E110...40///...		4	0.36	0	16	15							
E110...45///...		4.5	0.41	0	14	13							
E110...52///...		5.2	0.47	0	10	9							
E110...64///...	6.4	0.64	0	5	4.5								

## OPTIONS

Silver shading ring

Versions for use with industrial oxygen certified coils

ON REQUEST: Versions for use with fluid temperature at -40°C

COILS ③	ALTERNATING CURRENT 50/60Hz (V)								DIRECT CURRENT (V)			ELECTRICAL CONNECTION	CONNECTORS				
	12	24	48	110	120	220 230	240	380	12	24	48						
Series 2 Width 30	20A	20B	U25B	20C	20D	U25D	20E	20F	U25F	20G	200	U250	201	U251	202	DIN 43650A	PG9 CODE 10349000
Series 5 Width 36	52A	52B	U55B	52C	52D	U55D	52E	52F	U55F	52G	520	U550	521	U551	522	DIN 43650A	PG9 CODE 10349001

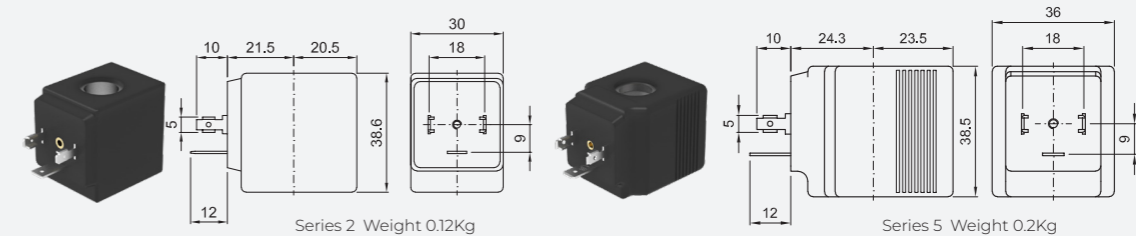

## DESCRIPTION

Insulation class  
Series 2 =F Series 5=H  
Voltage tolerance  
AC +15% -10%  
DC ± 10%  
Protection class  
IP65 with connector fitted  
IP00 without connector

## OPTIONS

Class H insulation (series 2)  
Cable attached  
Special coil voltage  
Special coil powers  
 certified coils  
(for coil details see section 8)

① Connection: B=1/4", C=3/8", D=1/2"

② Seal

③ Coil

④ Maximum allowable leakage <0.2NI/h

⑤ The maximum allowable pressure PS for steam is 9bar (gauge pressure) with PTFE seals and 2,5bar with EPDM seals

Example: E110BE35///20E EPDM seal , connections G1/4"  
Coil 230V 50/60Hz