

SERIES 123

Solenoid valve 2 way normally closed with servo-assisted piston suitable for air and water.
Its requested a minimum differential pressure of 0.7 bar.

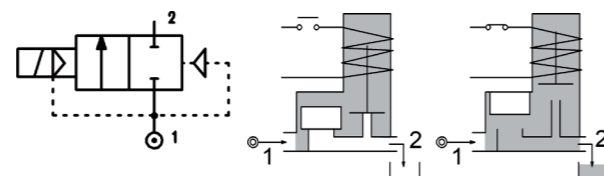

SPARE PARTS LIST

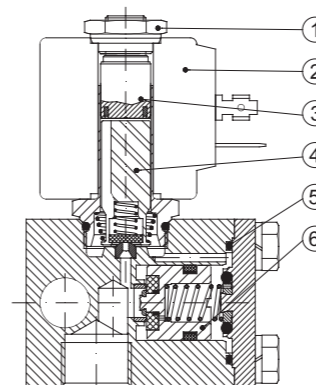

OVERALL DIMENSION

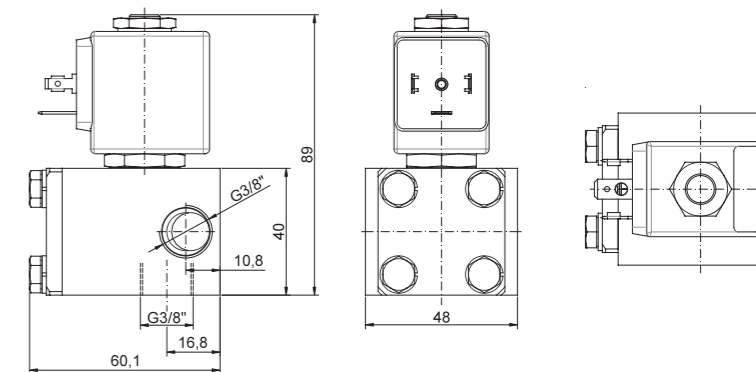

CONSTRUCTION

BODY AND COVER	Brass
ARMATURE TUBE	AISI 303
PLUNGER AND CORE	AISI 430FR
SPRINGS	AISI 302
PISTON	AISI 303
SEAL MATERIAL	main seal PTFE other FPM

FEATURES

Minimum differential pressure 0.7bar
Maximum allowable pressure PS 200bar
Maximum fluid viscosity 12cSt (mm ² /s)
Ambient temperature: from -10°C to +80°C according to the coil
Preferred mounting position with vertical coil above

CODE ②	CONNECTION G ISO 228	ORIFICE [mm]	KV m ³ /h	DIFFERENTIAL PRESSURE [bar]		NOMINAL POWER			COIL		SEAL	TEMP. RANGE [°C]	
				MIN.	MAX.	AC	VA	DC	SERIES	WIDTH			
													AC
E123CW07///...	3/8"	7	14	0.7	100	80	20	15	10	2	30	PTFE=W	-10 +95
					150	150	40	30	27	5	36		

② Coil
Maximum allowable leakage <0.2Nl/h

Example: E123CW07///20E PTFE seal
Coil 220-230V 50-60Hz

OPTIONS

Electroless nickel plating
UL certified coils

COILS ③	ALTERNATING CURRENT 50/60Hz (V)								DIRECT CURRENT (V)			ELECTRICAL CONNECTION	CONNECTORS				
	12	24	48	110	120	220 230	240	380	12	24	48						
Series 2 Width 30	20A	20B UL	U25B UL	20C	20D	U25D UL	20E	20F UL	U25F UL	20G	200	U250 UL	201	U251 UL	202	DIN 43650A	PG9 CODE 10349000
Series 5 Width 36	52A	52B UL	U55B UL	52C	52D	U55D UL	52E	52F UL	U55F UL	52G	520	U550 UL	521	U551 UL	522	DIN 43650A	PG9 CODE 10349001

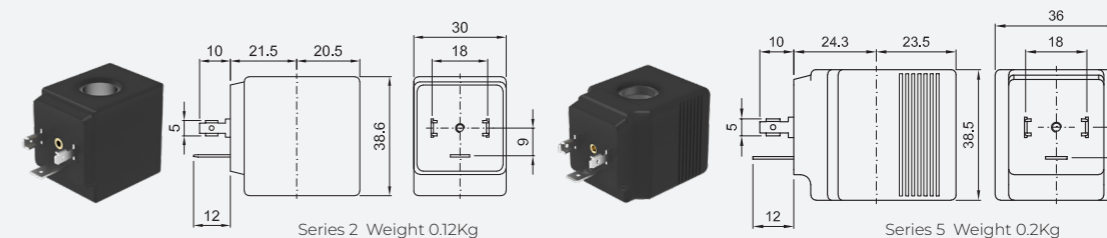

DESCRIPTION

Insulation class
Series 2 =F Series 5=H
Voltage tolerance
AC +15% -10%
DC ±10%
Protection class
IP65 with connector fitted
IP00 without connector

OPTIONS

Class H insulation (series 2)
Cable attached
Special coil voltage
Special coil powers
UL certified coils
(for coil details see section 8)