

SERIES 335

Solenoid valve 3 way normally closed direct acting poppet type, suitable for food applications and all compatible fluids.

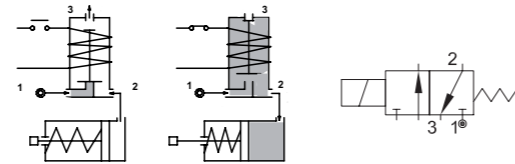

SPARE PARTS LIST

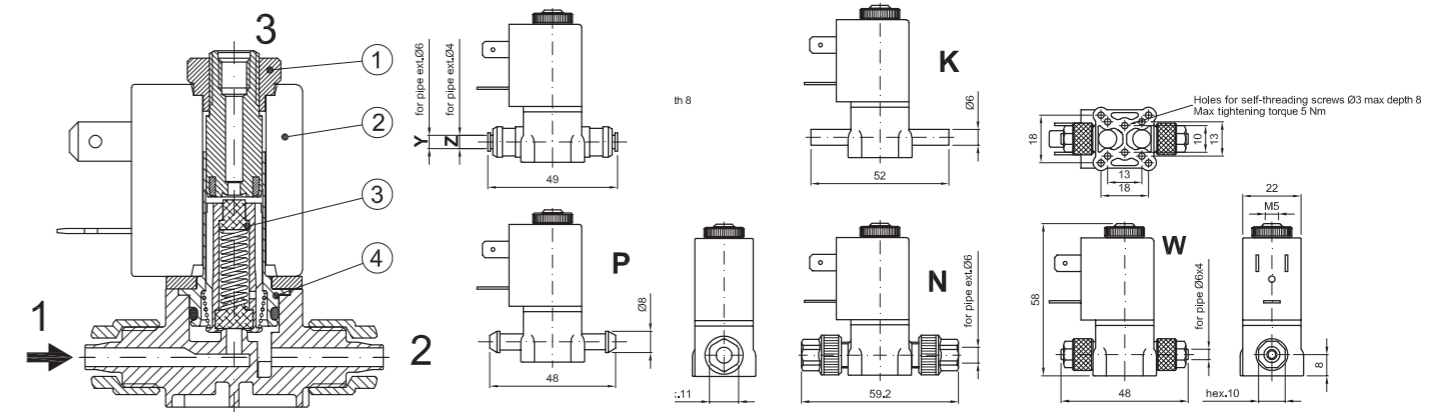

CONSTRUCTION

BODY	Thermoplastic polymer ACS, KTW, W270, WRAS, NSF, FDA certified
ARMATURE TUBE	Brass chemically nickel plated
PLUNGER AND CORE	AISI 430FR
SPRINGS	AISI 302
SEAL MATERIAL	NBR - FPM - EPDM

FEATURES

Maximum allowable pressure PS 15bar ②
Maximum fluid viscosity 25cSt (mm ² /s)
Ambient temperature: from -10°C to +80°C according to the coil
Universal mounting position

CONNECTION

K	N	P	W	Y	Z
SPIGGOT	G1/8" male thread with NUT for flexible pipes	HOSETAIL for flexible pipes	COMPRESSION for flexible and semiflexible pipes	PUSH IN for semiflexible pipes Øext 6	PUSH IN for semiflexible pipes Øext 4

CODE ①②③	CONNECTION G ISO 228	ORIFICE [mm]	KV m ³ /h	DIFFERENTIAL PRESSURE [bar]		NOMINAL POWER			COIL		SEAL ②	TEMP. RANGE [°C]	
				MIN.	MAX.	AC	VA	DC	SERIES	WIDTH			
													AC
E335... ..15///...	K-N-P-W-Y-Z	1.5	0.06	0	9	9	12	8	6.5	3	22	NBR=B EPDM=E FPM=V	-10 +90 -10 +140 -10 +140

Example: E335KB15///30B NBR seal SPIGGOT connection
Coil 24V 50/60Hz

② Seal
③ Coil
④ Only for connection "W" E335W.../1/...
⑤ The maximum allowable pressure PS for steam is 2.5bar (gauge pressure)
The maximum allowable pressure is related to the type of connection and pipe used
** The temperature range is related to the material of the seals (NBR, EPDM, FPM), and the valves' body.
Please contact us concerning the temperature range referred to the different types of connection.

OPTIONS

Stainless steel armature tube
Type N connection without nut
UL certified coils

COILS ②	ALTERNATING CURRENT 50/60Hz (V)								DIRECT CURRENT (V)			ELECTRICAL CONNECTION	CONNECTORS					
	12	24	48	110	120	220 230	240	380	12	24	48							
Series 3 Width 22	30A	30B	U35B	30C	30D	U35D	30E	V32E	30F	U35F	30G	300	U350	301	U351	302	DIN 46244	PG9 CODE 10348000

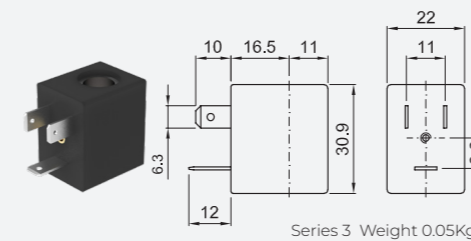

DESCRIPTION
Class F insulation
Voltage tolerance
AC +15% -10%
DC ± 10%
Protection class
IP65 with connector fitted
IP00 without connector
Continuous service ED100%

OPTIONS
Class H insulation
Cable attached
Special coil voltage
Special coil powers
UL certified coils
(for coil details see section 8)